

Eagle 4600 Side Shift Wheel Trencher

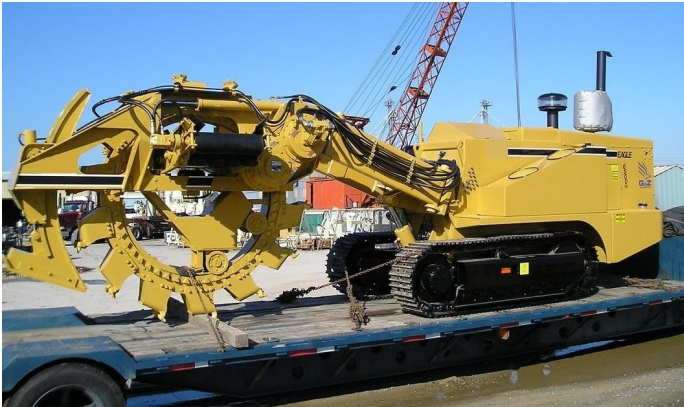

Primary Applications: Roadside Drainage & Utility Construction

Specifications:

Cat Tier 4 Diesel Engine @ 175 HP, All Hydraulic Drives, GPS Compatible

4' Depth x 12/24" Width Cut, Carbide Conical Teeth, Hydraulic Crumb Shoe

Cat D4 Size U/C, 12" TG Track Pads, 8' x 24" Conveyor, Auto Leveling

Truck Loading Conveyor, Weight: 35,000 lbs

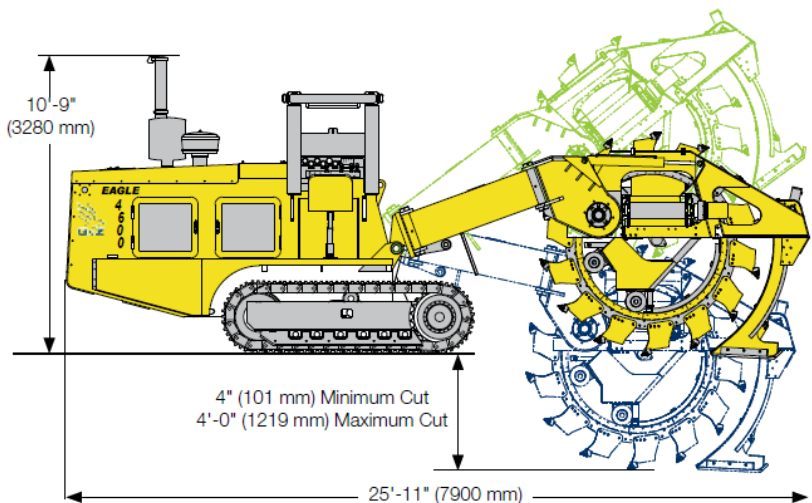
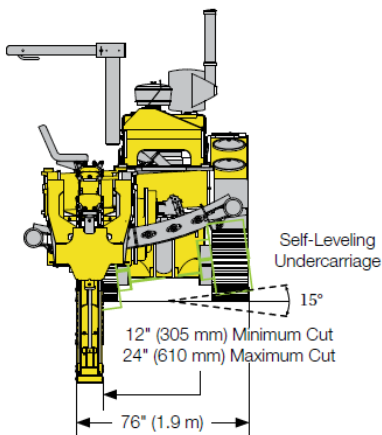

www.EagleTrenchers.com