

Eagle 5500 Wheel Trencher



Primary Applications: Irrigation & Utility Construction

Specifications:

Cat C3.4B T4F Diesel Engine @ 115 HP, All Hydraulic Drives, GPS Compatible

5' Depth x 22" Width Cut, X156 Dirt Teeth, Hydraulic Crumb Shoe

Cat D3 Size U/C, 12" Triple Grouser Track Pads, 8' x 24" Conveyor

Weight: 24,500 lbs

Options: Cab, Dozer Blade, Berm Scrapers

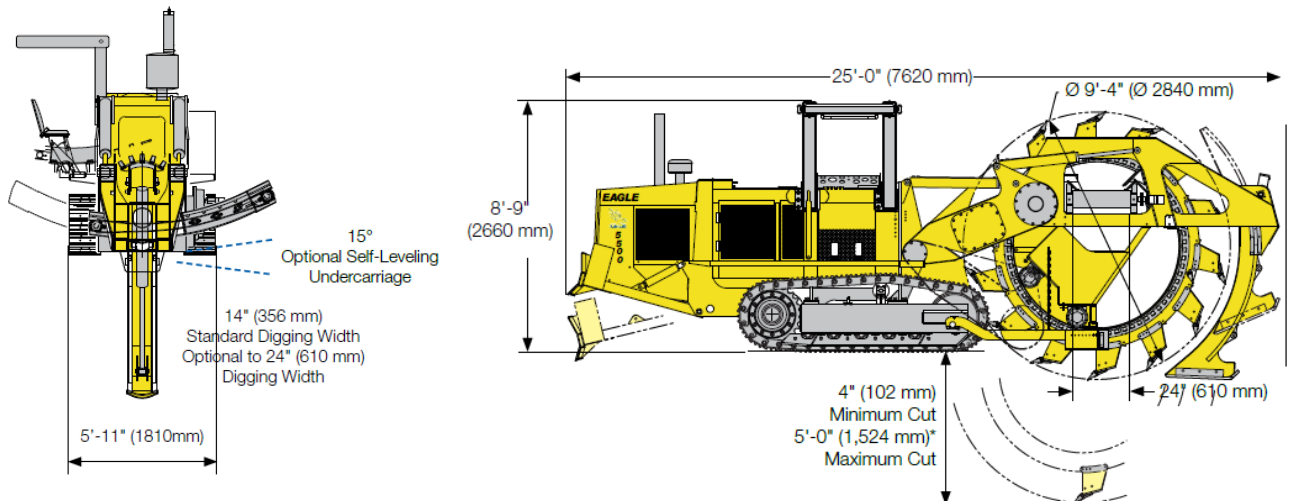

www.EagleTrenchers.com

(909) 615-4037

