

Eagle 6600 Side Shift Wheel Trencher



Primary Applications: Roadside Drainage & Utility Construction

Specifications:

Cat C7.1 T4F Diesel Engine @ 275 HP, All Hydraulic Drives, GPS Compatible

6' Depth x 18/24" Width Cut, X156 Dirt Teeth, Hydraulic Crumb Shoe

Cat D4 Size U/C, 16" TG Track Pads, 8' x 24" Conveyor, Leveling

Weight: 50,000 lbs

Options: Cab, Truck Loading Conveyor

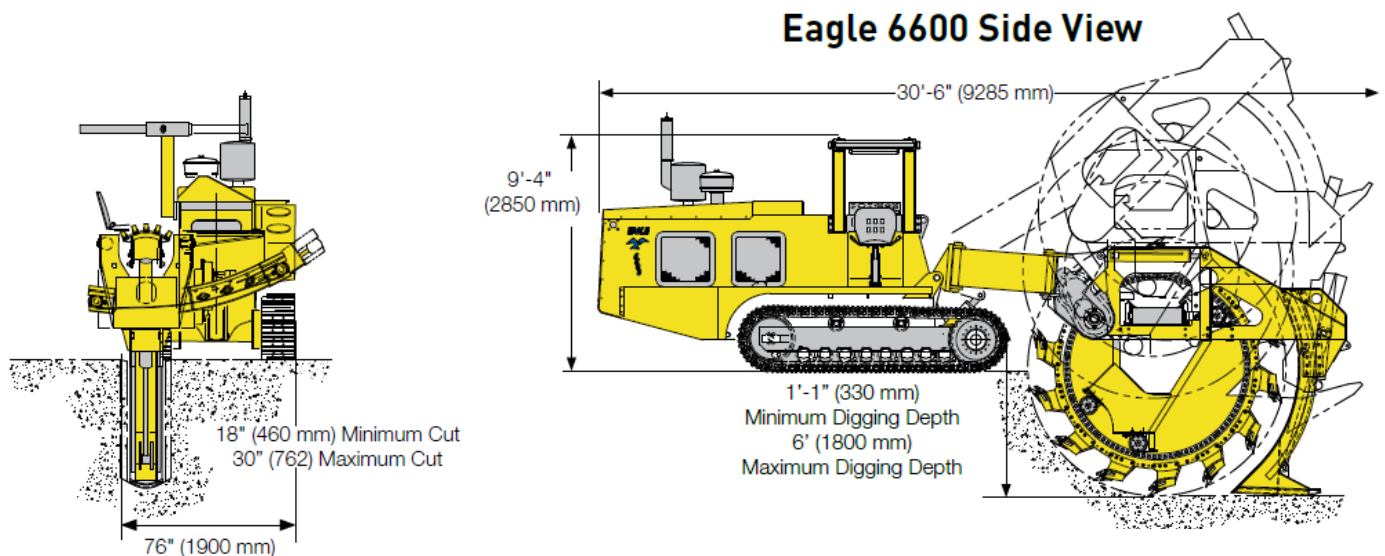

www.EagleTrenchers.com