

# Eagle 8500 Wheel Trencher



**Primary Application: Pipeline Construction**

**Specifications:**

**Cat C9.3 T4F Diesel Engine @ 350 HP, All Hydraulic Drives, GPS Compatible**

**8' Depth x 30/48" Width Cut, X156 Dirt Teeth, Fixed Crumb Shoe**

**Cat D5 Size U/C, 24" SG Track Pads, 36" x 10' Conveyor**

**Weight: 75,000 lbs**

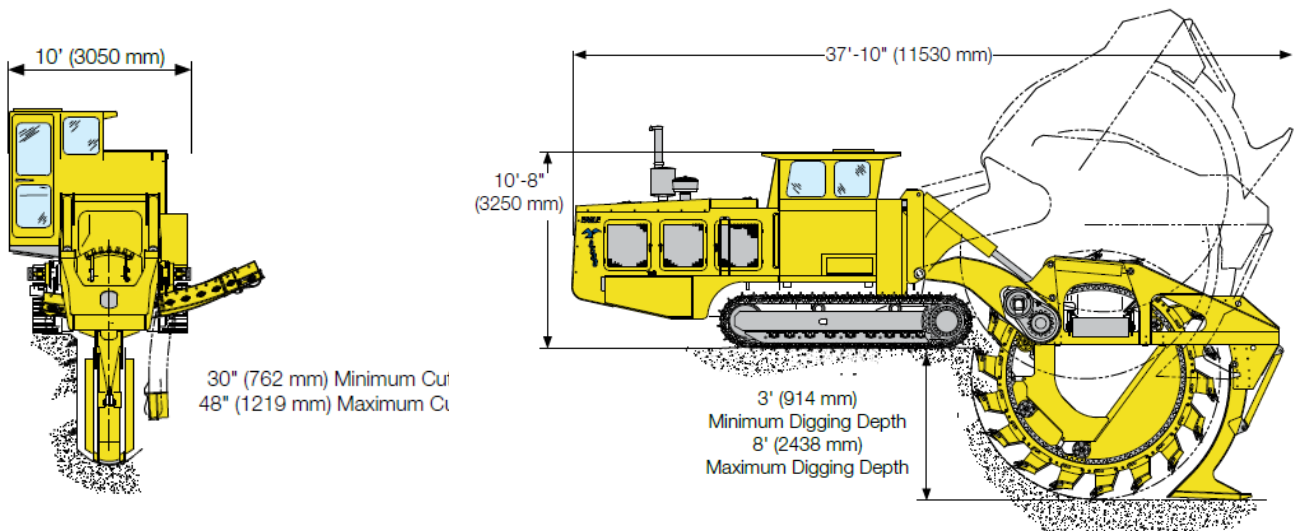

[www.EagleTrenchers.com](http://www.EagleTrenchers.com)

**(909) 615-4037**

